

Rigid Inflatable Boats



www.parkerribs.com





Parker Poland Sp.z o.o. is a wholly owned subsidiary of A.H.Parker & Sons (Gt. Britain) Ltd. and has an enviable reputation as one of the major producers of RIBs (Rigid Inflatable Boats) and GRP boats in Poland. It is accredited with AQAP 2120-2009 and ISO 9001:2008 and has supplied large numbers of RIBs to the quality-conscious commercial market and to leisure users. Parker RIBs are used in many countries by organizations such as Special Forces, Anti-terrorist Units, Army, Navy, Fishery Protection, Customs, Border Guards, Police, Fire Departments, Coast Guards and SAR organizations. Parker's larger Baltic RIBs are also becoming extremely popular in the growing market for professionally operated SeaSafari tourist and tripper boats.

The Czosnow facilities have an area of 10,000 m². The building (which is 1800m²) includes the offices, show room, service centre and spare parts warehouse. A new manufacturing hall was completed at the factory in Ostroda in 2013. RTM and infusion techniques are used, and only the best materials go into Parker's manually and painstakingly laminated RIB hulls.

The Ostroda plant also uses computer controlled multi axis milling machinery for the manufacture of plugs and tooling, ensuring maximum precision and top quality finish. There's an indoor tank for full pre-delivery testing.

The ever-increasing popularity of Parker RIBs with leisure users, rescue services and other professionals both in Poland and elsewhere in the world provides undeniable proof of Parker quality and reliability. An extensive network of overseas dealers (see website for current list) ensures an expert and professional service to Parker clients wherever they are.

Parker RIBs combine the best of both worlds – leisure comfort and commercial durability - without compromising either. Parker's careful development over the years means we have the balance just right.



The hull shape and construction provide tough, soft riding, seaworthy craft whose dynamics match anything in the market place; whilst the on-deck consoles, seating and general ergonomics have come from evaluating thousands of hours on the water in varying conditions to establish what really works. This is then incorporated into the entire Parker range.



Parker 510



The smallest of the Parker range, the 510 packs a lot into its length. A deep V hull provides a smooth, dry ride and the deep interior of the craft ensures that occupants are secure when the going gets tough. Top quality 'Hypalon' fabric is used for the 0.45m diameter tubes which - combined with excellent build quality - makes the Parker 510 a tough, no nonsense outboard-propelled all-rounder.

Technical Data



Length (overall)	5,10 (m)	Number of chambers	5	Twin outboard installation	-	Stainless steel under deck tank	40 ltr or 25 l (portable)
Internal length	4,06 (m)	Tube material	Hypalon	Recommended inboard diesel	-	Wheelhouse Cabin	-
Beam (overall)	2,3 (m)	Single outboard installation	60 HP 4 stroke, 90 HP 2 stroke	Maximum persons	6	CE certification	Yes
Beam internal	1,23 (m)						
Tube diameter	0,45 (m)						



Parker 650



The Parker 650 is an upgrade of the very popular Parker 630 model and is available with either single or twin outboards or diesel inboard. The latest super economical and lightweight Mercury Diesel QSD 2.0 (150 or 170HP) with the Alpha One or Bravo 1 sterndrive, Smartcraft Engine Management and Digital Throttle and Shift levers is proving incredibly popular. It achieves in the region of 36/38 knots, yet burns as little as 8 litres per hour at a comfortable cruising speed of 28 knots. The 650 has one of the smoothest and driest rides of any RIB under 7m and is equally at home as a general-purpose family runabout or as a serious offshore cruising RIB. It's very much a performance craft for extended cruising and for commercial, military or security use.

For rescue applications the Parker 650 can be fitted with self-righting systems and twin Mercury 90 ELPTO outboard engines with Post Immersion Start systems.

Technical Data



Length (overall)	6,50 (m)	Number of chambers	5	Twin outboard installation	2 x Mercury 60 HP 4 stroke 2 x Mercury 90 ELPTO 2 stroke	Stainless steel under deck tank	110 or 150 (L), o/board 2 x 110 in option
Internal length	4,92 (m)	Tube material	Hypalon	Recommended stern drive diesel	Mercury Diesel QSD 2.0 (150 / 170 HP)	Wheelhouse Cabin	Yes
Beam (overall)	2,49 (m)	Single outboard installation	min. 115 HP standard 150 HP, max. 200 HP 4 cyl	Maximum persons	8	CE certification	Yes
Beam internal	1,39 (m)						
Tube diameter	0,45 (m)						



Parker 680 Jet



The Parker 680 Jet was specially designed for Parker RIBs by world-renowned UK naval architect Adam Younger. Parker specified the length of the craft and propulsion package (water jet only was required). The performance on the initial trials surprised us all. A speed of 40knots was achieved with superb sea keeping qualities. This model is ideal for shallow coastal water operations or for lakes and rivers. It is the perfect boat for Military and Navy use, search and rescue applications, Harbour Patrol, Police and Maritime Security work with or without cabin. The range is being extended with a single / twin outboard version.

Technical Data



Length (overall)	6,80 (m)	Tube diameter	0,36 (m) at bow, 0,46 at stern to midships	Dry weight	1300kg	Stainless steel under deck tank	150 (L)
Internal length	6,30 (m)	Number of chambers	5	Recommended inboard diesel	Mercury Diesel DTI 3.0 (265HP) with gearbox and water jet drive	Wheelhouse Cabin	Yes
Beam (overall)	2,75 (m)	Tube material	Hypalon	Maximum persons	12	CE certification	Yes, Category B
Beam internal	1,83 (m)						



Parker 750 Baltic



Tough and capable, designed for twin engine installation, the Baltic models are now very much established in the Parker RIB range and are offered to the professional, commercial and military markets where strength, space and seaworthiness are the priority. The superb handling features of the successful RS range have been incorporated into this larger and stronger design to provide the ultimate in offshore use. With its substantial beam the 750 Baltic easily carries two large outboards or twin Mercury Diesel QSD 2.0 diesel stern drives or single QSD 4.2 and her 58cm diameter buoyancy tubes provide immense safety and fendering when the going gets tough.

Technical Data



Length (overall)	7,50 (m)
Internal length	6,38 (m)
Beam (overall)	3,16 (m)
Beam internal	1,85 (m)
Tube diameter	0,58 (m)

Number of chambers	5
Tube material	Hypalon ORCA
Single stern drive installation	diesel QSD 4.2 270/320 HP max

Twin outboard installation	2 x 150 HP
Recommended stern drive diesel	2 x QSD 2.0 170 HP
Maximum persons	12

Stainless steel under deck tank	2 x 120
Wheelhouse Cabin	No
CE certification	Yes



Parker 750 RS



This performance craft offers one of the most comfortable rides offshore by utilizing an ultra-deep "V" hull. This produces the most predictable, best handling and most capable RIB of this size. There is no slamming effect; the RS just cuts into the waves like a "knife into butter". The Parker 750RS range is for those who put performance, comfort and safety above all else. Whether extended cruising with Mercury diesels or blasting around at 40+ knots with the economical Mercury Optimax or Verado four-stroke outboards, the Parker 750RS will satisfy the most demanding owners.

Technical Data



Length (overall)	7,50 (m)	Number of chambers	5	Twin outboard installation	2 x Mercury 115 KM max 2 x 150 KM	Stainless steel under deck tank	220 l
Internal length	6,36 (m)	Tube material	Hypalon ORCA	Recommended inboard diesel	QSD 4.2 270/320 HP max	Wheelhouse Cabin	Yes
Beam (overall)	2,75 (m)	Single outboard installation	Mercury 225/250/ max KM 300	Maximum persons	12	CE certification	Yes
Beam internal	1,46 (m)						
Tube diameter	0,53 (m)						



Parker 900 Baltic



Tough and capable, designed for twin engine installation, the Parker 900 Baltic is well established in the Parker range and is offered equally to the commercial, military, Sea Safari and leisure markets where strength, space and seaworthiness are the priority. The best handling features have been incorporated into this large and strong design that is ideal for offshore use. With its substantial beam the 900 Baltic carries two large outboards or single diesel stern drive while its 58cm diameter buoyancy tubes provide safety and fendering in heavy conditions. With an exceptionally high flared bow and massive buoyancy tubes the Parker 900 Baltic is ideal for serious commercial and military work and (thanks to its large fuel tank capacity) for long distance cruising. The 900 Baltic is also a first choice RIB for professional Sea Safari operators. The full wheelhouse version of the Parker 900 Baltic is capable of staying out at sea in the worst of weather whilst keeping the crew dry and comfortable. Equally suited to both commercial and leisure applications, this very practical and attractive wheelhouse model adds a new concept to Parker's RIB culture.

Technical Data



Length (overall)	9,00 (m)	Number of chambers	7	Stern drive diesel	1 x 350 HP or 2 x 270 HP max 2 x 320 HP	Stainless steel under deck tank	2 x 220 plus in option 2 x 110 for cabin version 2 x 250
Internal length	8,95 (m)	Tube material	Hypalon ORCA	Maximum persons	18	Wheelhouse Cabin	Yes
Beam (overall)	3,16 (m)	Outboard installation	2 x 225/250 HP or 2 x 300 HP max	CE certification	Yes		
Beam internal	1,85 (m)						
Tube diameter	0,58 (m)						



Parker 900 RS



The Parker 900RS is a high performance craft offering one of the most comfortable offshore rides thanks to its ultra deep V hull which has been developed into one of the most predictable, best handling and most capable RIBS of this size. The Parker 900RS range is for those who put performance, comfort and safety above all else and whether extended cruising with Mercury diesels or blasting around at 50+ knots with the latest economical Mercury Optimax or Verado four-stroke outboards, the Parker 900RS provides maximum pleasure afloat.

Technical Data



Length (overall)	9,00 (m)	Number of chambers	7	Twin outboard installation	2 x 300 max HP	Stainless steel under deck tank	2 x 220 (l)
Internal length	7,86 (m)	Tube material	Hypalon	Maximum persons	18	Wheelhouse Cabin	Yes
Beam (overall)	2,83 (m)	Single stern drive diesel	QSD 4.2 350HP max	CE certification	Yes		
Beam internal	1,53 (m)						
Tube diameter	0,53 (m)						



Parker 1000 Baltic



The Parker 1000 Baltic shares the features and dynamics of the 900 but is extended to give more space and carrying capacity. The Parker1000 Baltic delivers the same performance as the 900, whilst handling extra payload with greater reserves of buoyancy. The RIB can be powered by twin outboards (up to 400HP each) or twin diesel stern or jet drive (up to 350HP each.)

The 1000 Baltic is a logical step forward for those who demand that little bit extra; and is available as an open RIB or with a cabin/wheelhouse option. For twin diesel installations the deck height is increased by 12cm to give the craft more buoyancy and increased capacity fuel tanks. This is standard for all Parker Arrow and Parker Baltic Cruiser models since these models share the same hull.

Technical Data



Length (overall)	9,70 (m)	Number of chambers	7	Stern / jet drive diesel	2 x 320/350 HP
Internal length	8,95 (m)	Tube material	Hypalon ORCA	Maximum persons	18
Beam (overall)	3,16 (m)	Twin outboard installation	2 x 250/300 HP max 2 x 400 HP	Wheelhouse Cabin	Yes
Beam internal	1,85 (m)			CE certification	Yes
Tube diameter	0,58 (m)				



Parker Baltic cruiser



The Parker Baltic Cruiser 10 meter wheelhouse cabin RIB has been developed in cooperation with Askeladden Boats of Norway. It's a perfect marriage between the very successful Parker 1000 Baltic RIB and the Askeladden Commuter cabin.

This development is in response to ever-increasing demand from the leisure and commercial markets. The Parker Baltic Cruiser is a very capable long distance cross channel cruising RIB with on board sleeping facilities in the forward cabin. There is a separate WC compartment with hand wash basin. Teak flooring and laminated walls are standard. There is lots of storage space with an optional sink unit and small cooker located under the navigator's table and optional fridge under the helmsman's seat.

The Parker Baltic Cruiser is available with twin outboard (up to 400 HP each) or twin diesel stern drive engines (up to 370 HP each) and Parker's trademark extra outside steering position is also available as an option.



Technical Data



Length (overall)	9,70 (m)	Number of chambers	7	Maximum persons	18
Internal length	8,95 (m)	Tube material	Hypalon ORCA	Stainless steel under deck tank std	2 x 300 ltr o/b version 2 x 300 ltr stern drive version
Beam (overall)	3,16 (m)	Stern drive diesel	2 x 370 HP max	Wheelhouse Cabin	Yes
Beam internal	1,85 (m)	Outboard	2 x 400 HP max	CE certification	Yes
Tube diameter	0,58 (m)				



Parker Arrow



The stylish Parker Arrow Sports Cabin Cruiser enjoys the same hull as the Parker 1000 Baltic and Parker Baltic Cruiser. The performance of the Parker Arrow is second to none. With its superb sea keeping capabilities the Arrow has proven itself by offering a soft and dry ride. The Parker Arrow is available with both twin outboard or twin stern drive diesel installations and is ideal for long sea passages or cross channel cruises.

The cabin offers berths, a kitchen unit with sink, a separate cabin with sea toilet, basin and shower and - for chilly nights - there is the luxury of a Webasto heating system.

The cockpit seats eight people in the outboard version and six people in the diesel stern drive version.

Technical Data



Length (overall)	9,70 (m)	Number of chambers	7	Stern drive diesel	2 x QSD 4.2 320/350 HP
Internal length	8,95 (m)	Tube material	Hypalon		
Beam (overall)	3,16 (m)	Twin outboard installation	2 x 300/350/400 HP max	Maximum persons	18
Beam internal	1,85 (m)				
Tube diameter	0,58 (m)				



Parker 1200 Enforcer

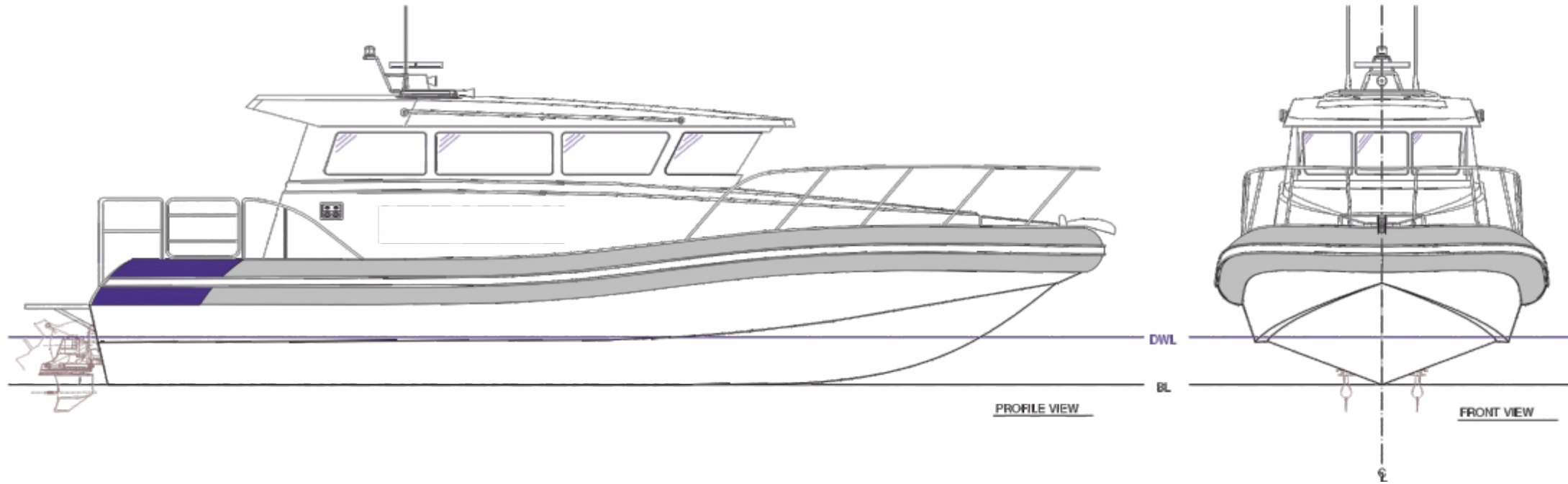

New to the Parker range the 12m Enforcer is available as a cabin or open version. The interior of the cabin version is designed and built to the customer's exact requirements. The forward area accommodates a Galley, WC, storage area and sleeping accommodation for two persons if required. The propulsion is by means of twin stern drive Mercury Diesel TDI 4.2 370 HP or equivalent to a maximum of 800 HP. The Parker 1200 Enforcer is marketed as an offshore mother craft, Police, Coast Guards, water ambulance, all weather passenger carrying RIB etc

Technical Data

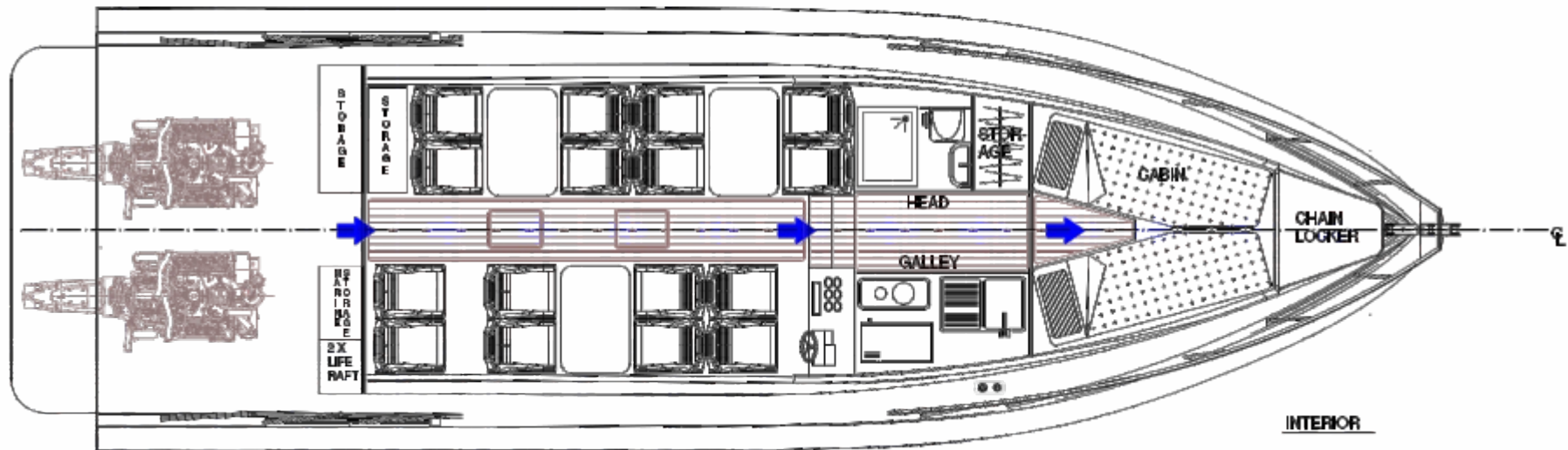
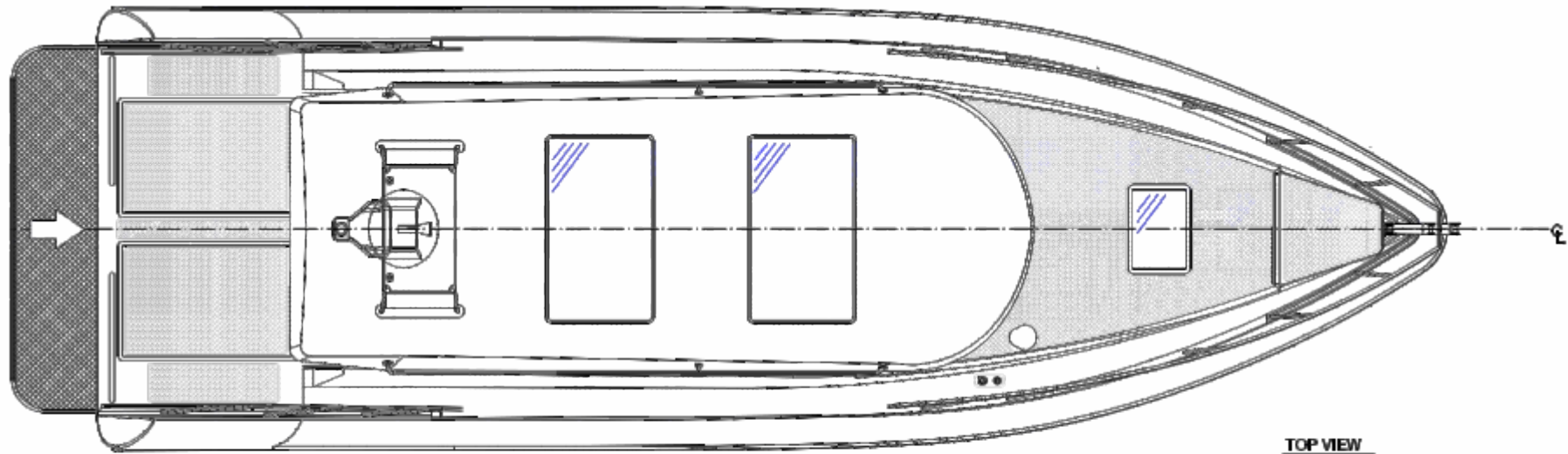

Length (overall)	12,00 (m)	Number of chambers	9	Standard stern drive diesel	2 x TDI 4.2 370 HP
Internal length	10,68 (m)	Tube material	Hypalon ORCA	Maximum persons	18
Beam (overall)	3,90 (m)	Twin outboard installation	2 x 400 HP max	Wheelhouse Cabin	Yes
Beam internal	2,97 (m)			CE certification	Yes
Tube diameter	0,55 (m)				



Parker 1600 Interceptor



Flagship of the Parker range, the Parker 16m Interceptor is a serious offshore patrol, rescue or crew delivery craft designed to tackle the roughest conditions and provide safe and comfortable accommodation at sea. From its streamlined fully enclosed wheelhouse and cabin to its superb offshore hull, the new Interceptor has been conceived to provide an exceptional combination of performance and sea keeping ability along with maximum protection for the crew and passengers.

The Parker 1600 Interceptor is available with twin diesels with jet drive (maximum 715 HP each) or 4 x 400 HP outboard engines. The wheelhouse is separate from the main cabin and can comfortably accommodate a four-man crew. The main cabin as standard has a separate WC compartment with sea toilet, basin and shower unit. There's also a galley. A separate cabin to sleep up to four people is available as an option. Bench seating along the cabin sides accommodates 24 people. Alternatively forward facing single seats or bench seats can be specified or custom built interior. Available in the open version in a length from 12.50 to 16.0 mtr with twin diesel sterndrives or multi outboard engine configuration.

Technical Data



Length (overall)	15,5 (m)	Number of chambers	11	Max jet drive diesel	2 x QSM11 715 HP
Internal length	14,0 (m)	Tube material	Hypalon ORCA		
Beam (overall)	4,35 (m)	Outboard installation	4 x Mercury Verado 350 HP max	Maximum persons	4 crew + 26 survivors
Beam internal	2,95 (m)				
Tube diameter	0,70 (m)				



Parker Military RIBs



Parker is probably the fastest growing RIB producer in Europe and it's no accident that ever more commercial, military, and rescue users are acquiring Parker RIBs. Parker RIBs have proved to be tough and reliable so are regularly used for Military applications. The most popular models come from Parker's outstanding Baltic range and are available with standard deck layout and equipment or as bespoke custom-made craft built to individual requirements.

Propulsion options offered include twin diesel with jet drives, twin diesel stern drives, twin outboards and - with the smaller models - single stern drive, water jet or outboard.



Parker Military RIBs





Parker Seasafari RIBS



Sea Safaris offer a thrilling experience, combining excitement and adventure with the chance to observe and study sea life, bird life or even the geology of the cliff and rock formations of various coastal areas. Parker Baltic RIBs operate successful Sea Safaris for companies operating from places as varied as the Baltic coast, Italian Riviera, Iceland, Jurassic coast of Dorset, Wales and Lanzarote. Sea Safari tours are becoming increasingly popular and Parker's specially designed and custom-built 12 + 2 seater RIBs are frontrunners in this fast-growing market. The Parker Baltic hull offers the passengers a very soft ride and has proved to be one of the best available on the market today.

Equipment



Commercial specification for the tube reinforcement



Heavy duty samson post



Quick Eagle windlass model installed in anchor locker



Mariner Console . Armrests in option



Neptune Console



Rear bench seat on Baltic models

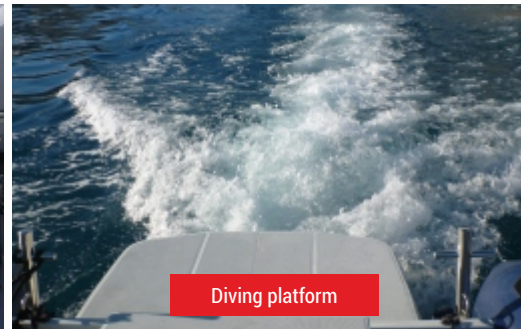

Diving platform

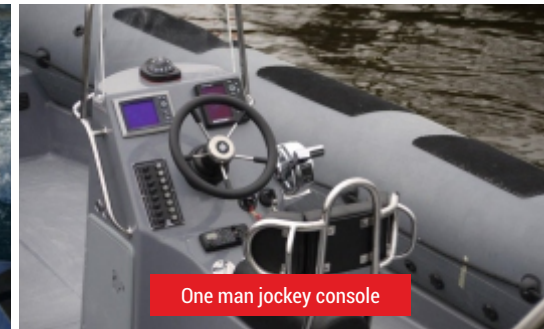

One man jockey console



Parker 680 Jet - Patrol console



Parker Baltic Cruiser - outside steering

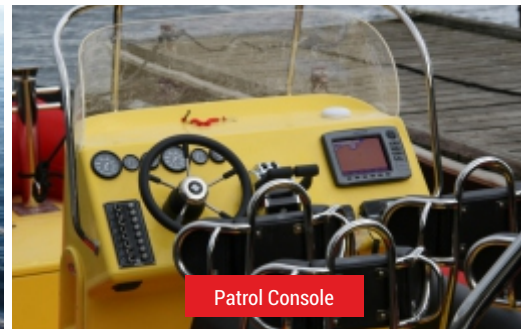

Patrol Console



T-Top & Liferaft arrangements



Sun bed on bow & Neptune console



Twin Mercury Diesel QSD 2.0



Parker 680 Jet - Mercury Diesel TDI 3.0 Engine



Twin outboards on Baltic model



LOWRANCE

SIMRAD

Radio & Navigation Equipment



Simrad NSE 8



Simrad NSE12



Lowrance HDS-9



Broadband 4G Radar



**RS35 DUAL HERO
Simrad RS35 VHF Radio**



Lowrance Link-8



Module Lowrance Uni-Dock
Module for use with SonicHub and all newer iPhone and Android phones

Radio & Navigation Equipment



SIMRAD TYPICAL INSTALLATION

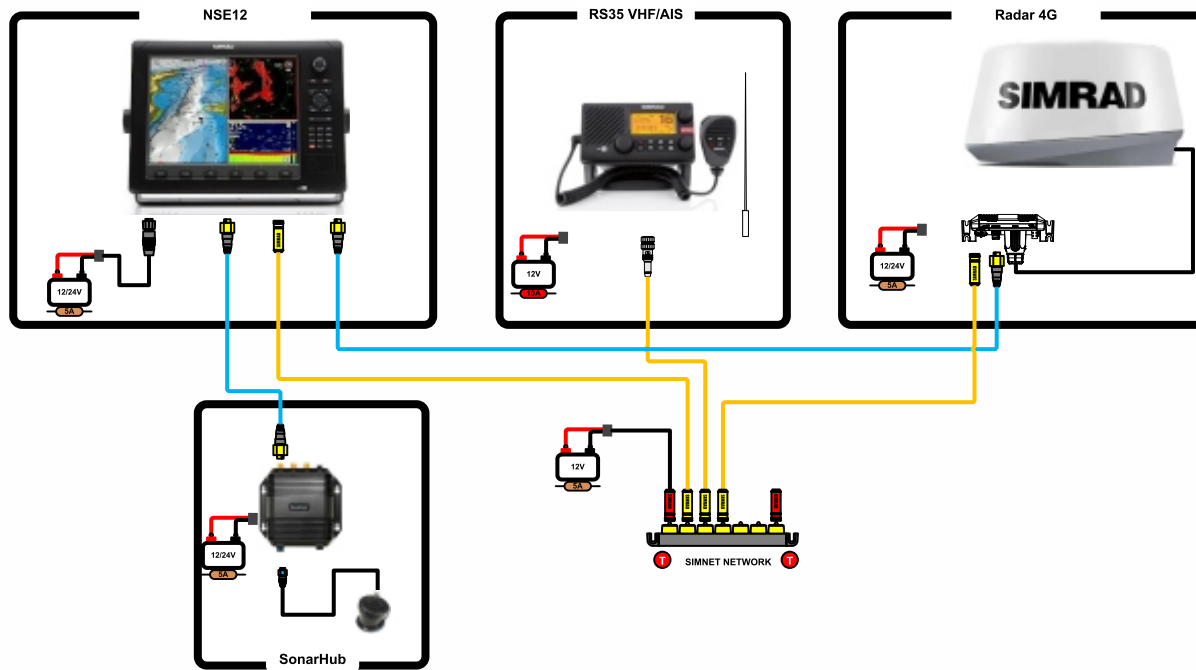

LOWRANCE TYPICAL INSTALLATION

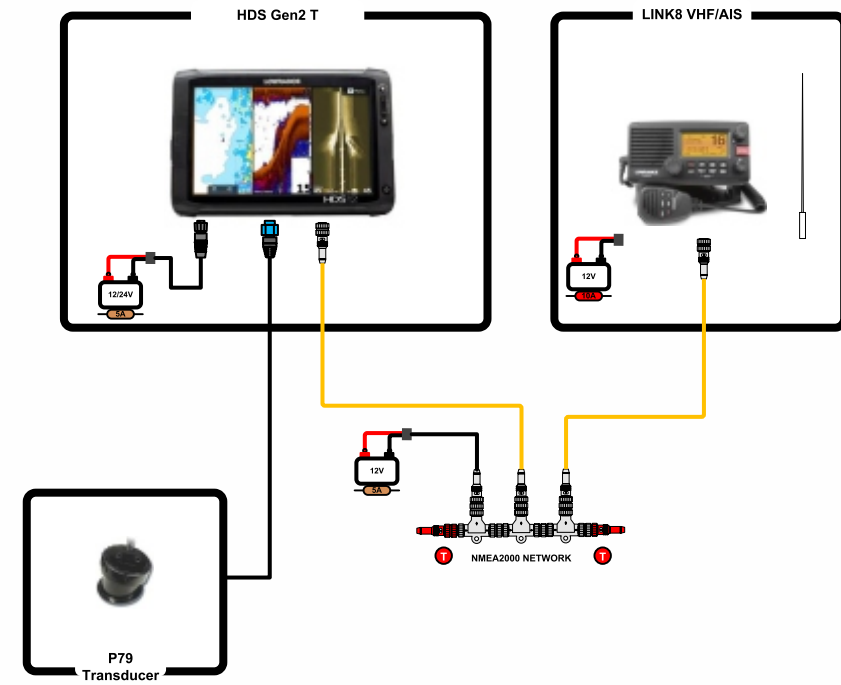

- Drop cable
- Backbone
- Ethernet
- Other connection
- T Network terminator
- NMEA2000 connector Male
- NMEA2000 connector Female
- Simnet connector



A.H.Parker & Sons (Gt. Britain) Ltd

2 Rustic House, Hayes Lane
Slinfold, RH13 0ST
United Kingdom

+44 1403 780470

info@parkerribs.com



www.parkerribs.com

Parker Poland Sp. z o.o.

Cząstków Polski 171
Czosnów 05-152
Poland

+48 22 7851111

rib@parker.com.pl